



ROLL-UP DOOR INSTALLATION MANUAL



A&A Manufacturing Co., Inc.

2300 S. Calhoun Road
New Berlin, WI 53151
Phone: (262) 786-1500
Fax: (262) 786-3280
E-Mail: sales@aaman.com
www.gortitedoors.com

Before beginning installation, please:

- Carefully read the complete installation manual;
- Make sure the door opening is square and free of weld crowns or other obstructions;
- When unpacking, be careful not to scratch the door and/or other components;
- Refer to Figure #30, the assembly drawing to verify if all components are present.

Tools and Equipment needed:

- Tape Measure
- Marking Pen
- Fasteners (self tapping preferred)
- Drill
- Drill Bits: 11/64", 3/8" (lock rod option)
- Pliers
- Screwdriver or Allen Wrench Set
- Permabond® 910

Layout Mounting Holes

Gortite recommends pre-drilling the mounting hole's for all of the roll-up door components, however, the mounting holes can be drilled as the components are installed. Pre-drilling the holes requires temporarily mounting the roll-up door components in their respective locations, drilling the holes, removing the component, and reinstalling them when needed.

Step 1 – Pennant Plate Mounting

- A) Position the pennant plate as shown in Figure #1, mark the holes, and drill the holes using an 11/64" drill bit. Typical both sides of the cabinet.
- B) Pennant plates must be mounted to surfaces in the same plane and/or width as the door opening.

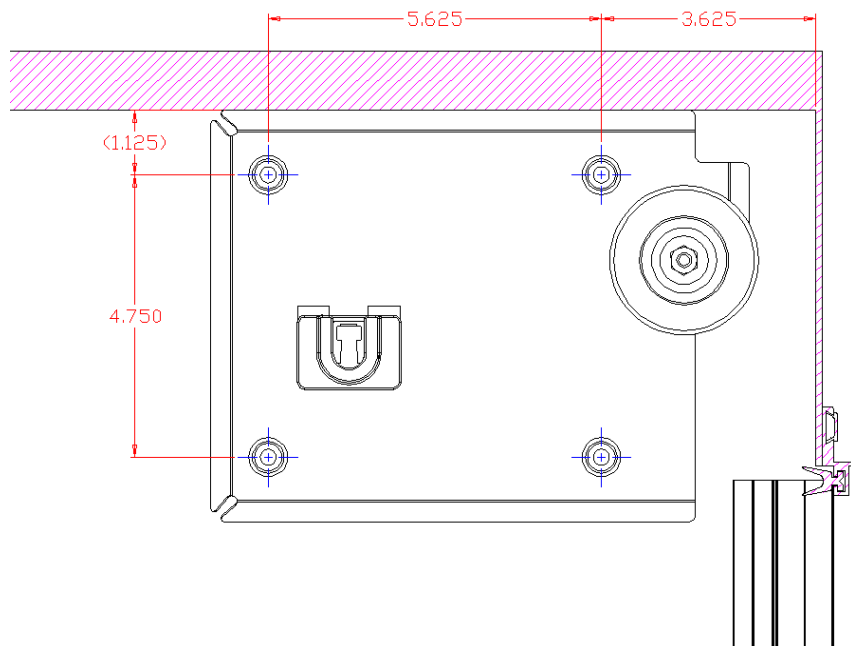

Figure #1

Step 2 – Sill Plate Mounting (Optional)

- A) Position the sill plate as shown in Figure #2. Mark the holes and drill 11/64” holes. If no pre-drilled holes then drill 11/64” holes 12” a part.

NOTE: Sill plate needs to be in position when mounting the side rails.

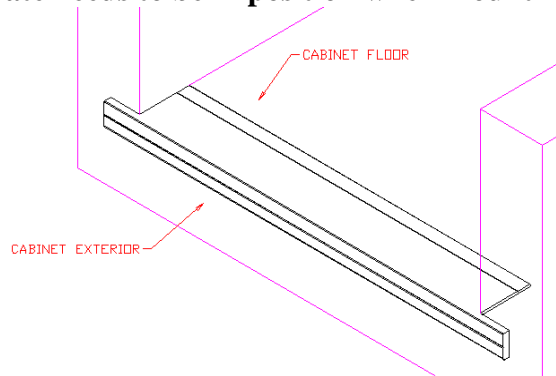

Figure #2

Step 3 – Side Rail Mounting

- A) Position the side rail as shown in Figure #3 with the bottom resting on the cabinet floor, or on top of the sill plate as in shown in Figure #4 with sill plate option.

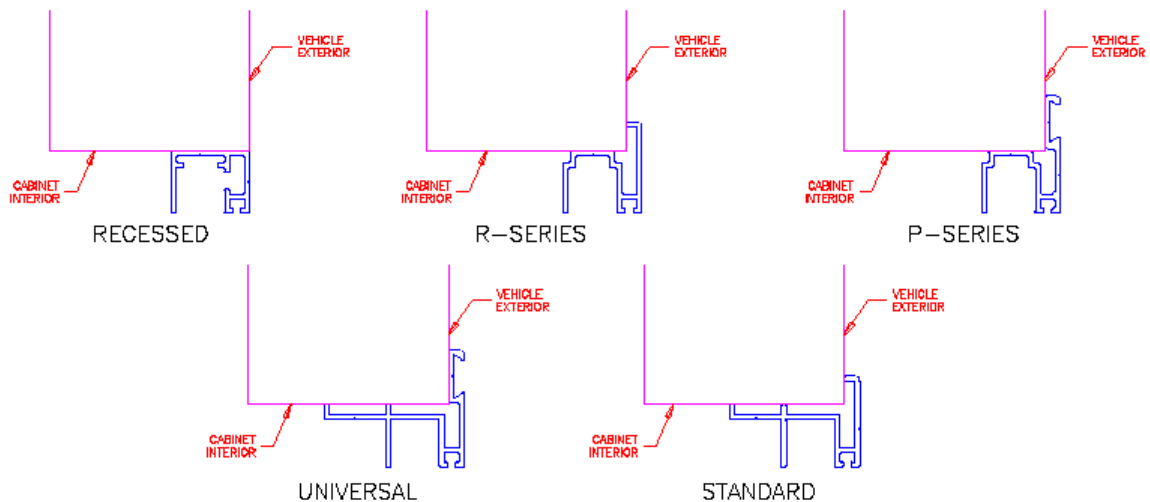

Figure #3

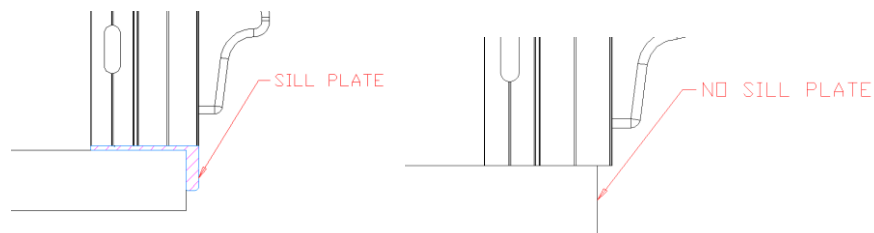

Figure #4

- B) Mark the holes and drill 11/64”. If side rail not pre-drilled then drill the holes approximately 12 inches apart through the side rail and cabinet. Typical for left and right side rails.
- C) For a manual lock, use the pre-drilled hole in the side rail as a guide to transfer the 3/8” hole into the side of vehicle body.

Step 4 – Top Rail Mounting

- A) Position the top rail against and flush with bottom edge of the header (approx. $\frac{1}{4}$ " above the side rails), and with the edges of the side rail. See Figure #5

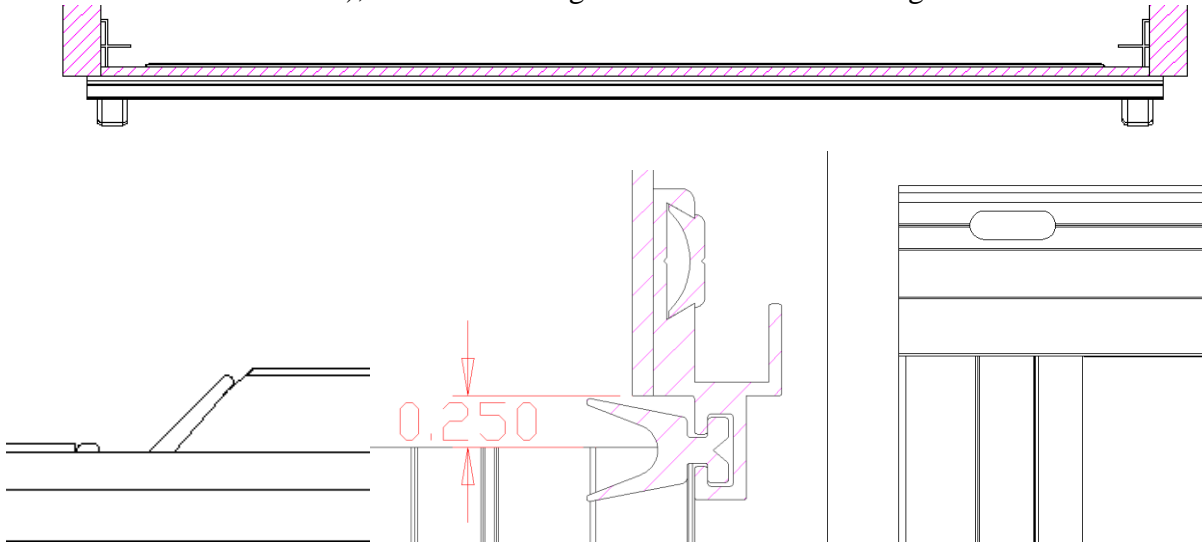

Figure #5

- B) Cut the top seal ends at an angle to fit between the side seals. See Figure #5.
- C) If no pre-drilled holes, then drill holes no more than 12 inches apart. The screws should not extend more than $\frac{1}{8}$ " into the compartment. See Figure #6

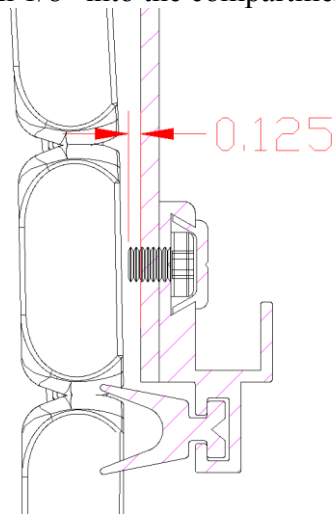
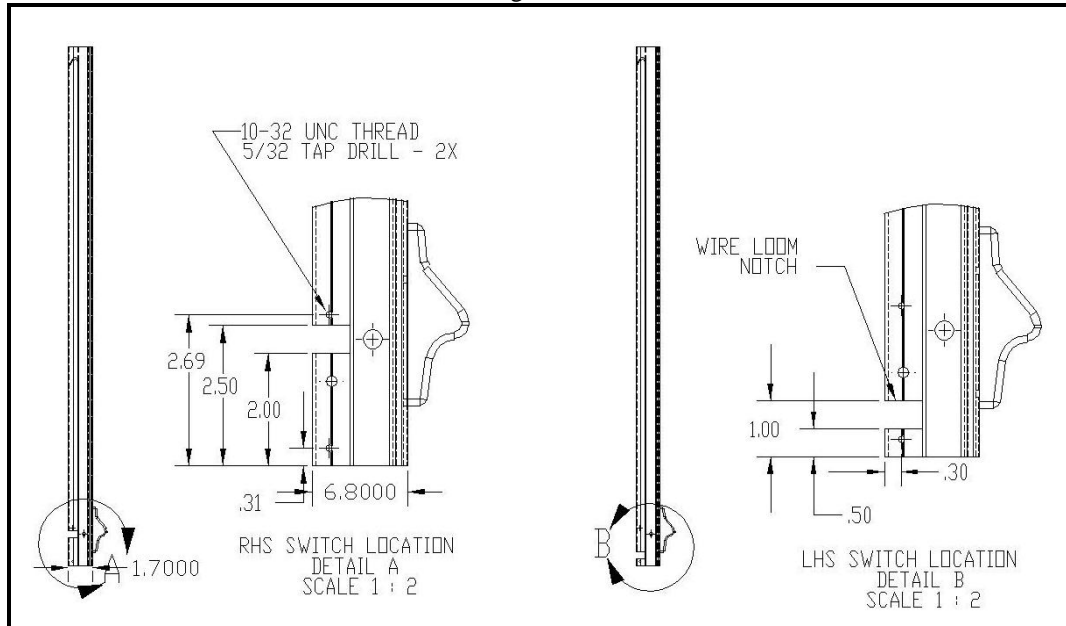

Figure #6

Step 5 – Door Ajar Switch Mounting (Standard and Universal Side Rail Only)

- A) Measure up from the bottom 1 1/8" and cut a 3/4" wide x 21/32" deep slot. See Figure #8

Figure #8



- B) Place the switch against the side rail and the bottom flush with the bottom of the side rail. Mark the holes, drill and tap for a #10-32 UNC BHCS. See Figure #8.
- C) When mounting the switch, be sure the notch is facing the side rail. See Figure #9.

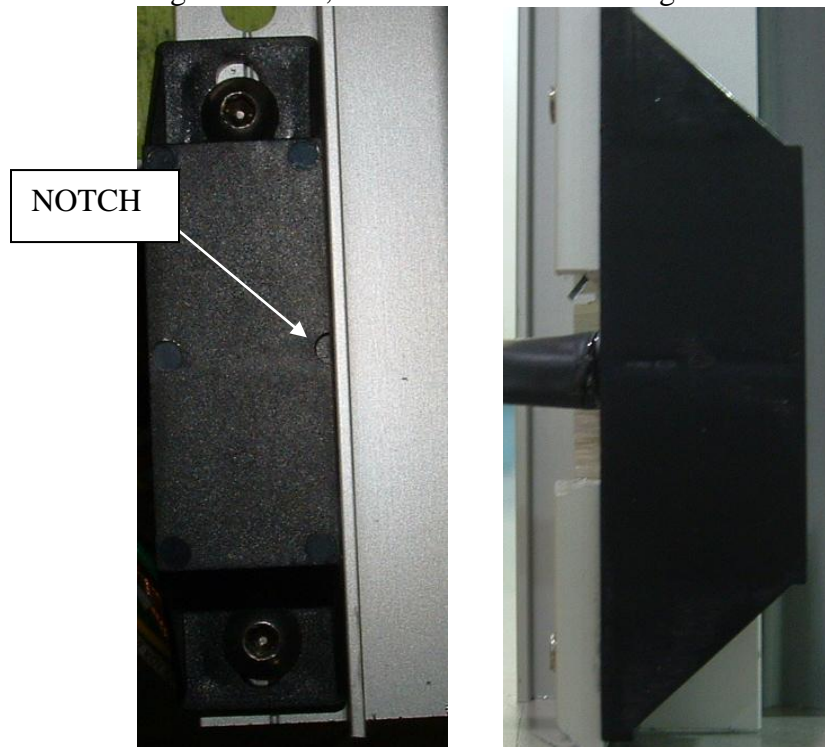
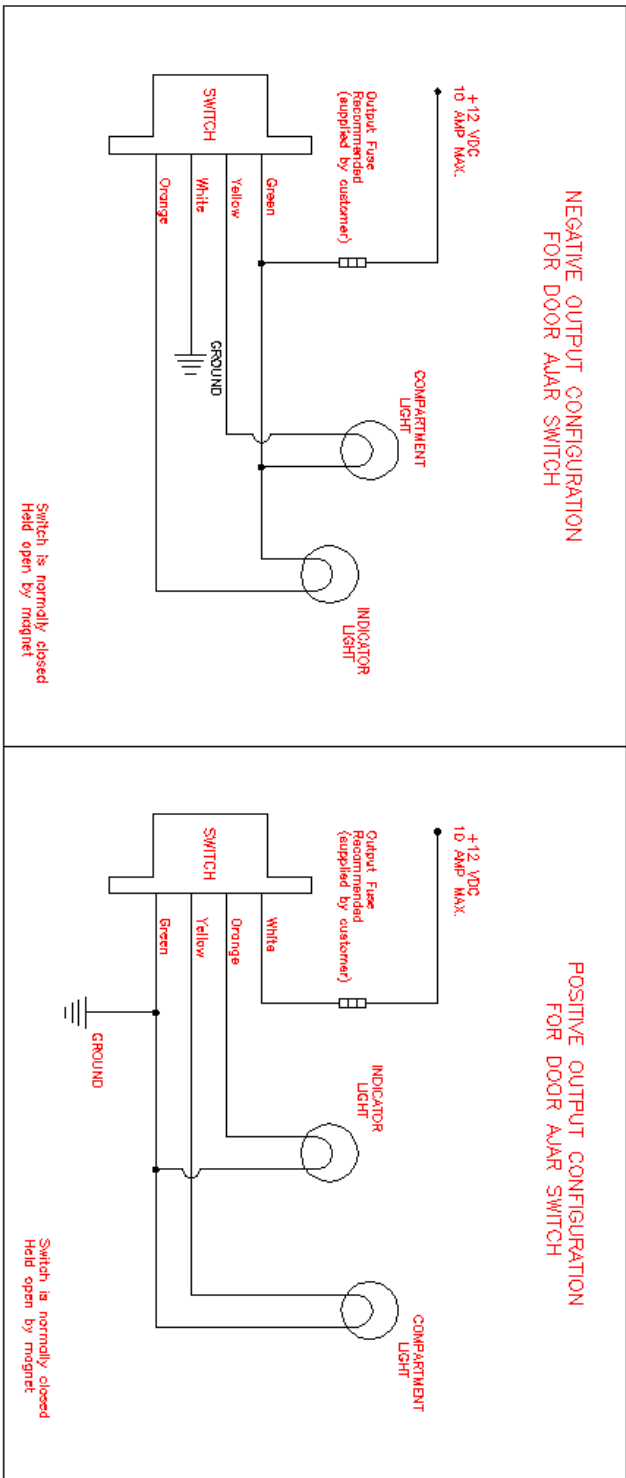

Figure #9

D) The wiring diagram is pictured in Figure #10

Switch Configurations



This switch has two separate—isolated outputs that can be used to provide power to compartment lights and cab indicator lights without the need for any additional components or switches.

The switch can be easily adapted to any existing wiring configuration and can be used with multiple or single cab indicator lights.

Figure #10

Step 6 – Door Installation

Roller Assembly Mounting

- A) If the pennant plates have been removed, then reinstall them.
- B) Place roller shaft into the arbors, with “Right Side” label to the right when facing the front of the compartment. See Figure #11

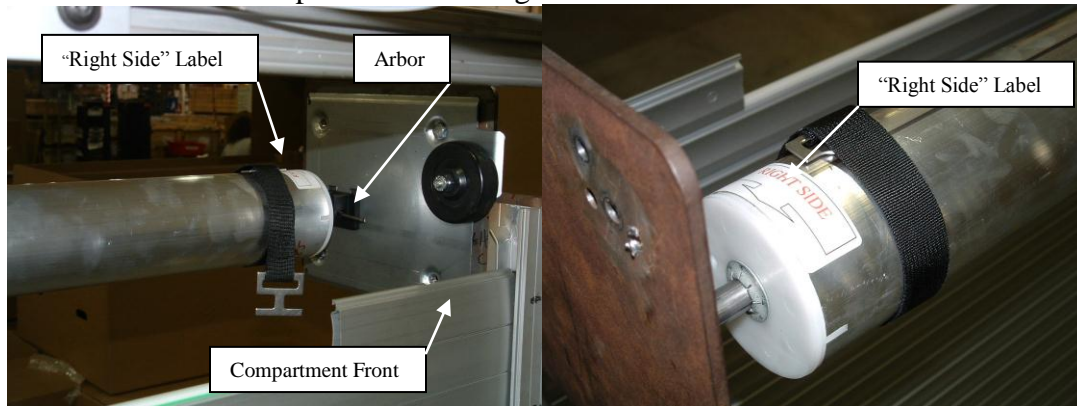

Figure #11

- C) Slide cotter pin through the arbor and shaft and bend around the arbor. Typical both pennant plates. See Figure #12.

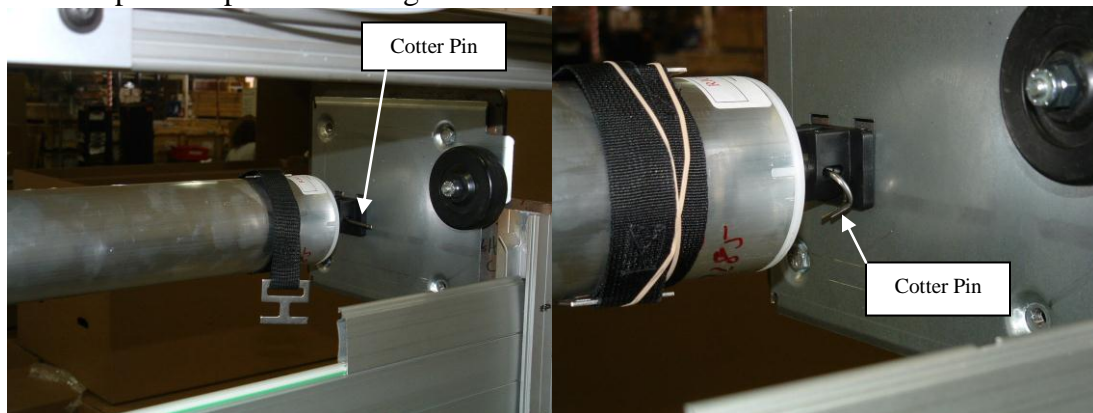

Figure #12

NOTE: Be sure to remove the side rails and top rail before installing door.

Shade Mounting

- A) Slide the mounting ribs over the idler wheel and roller assembly. Allow the door to hang behind the roller and insert that attachment clips into the mounting rib. See Figure #13

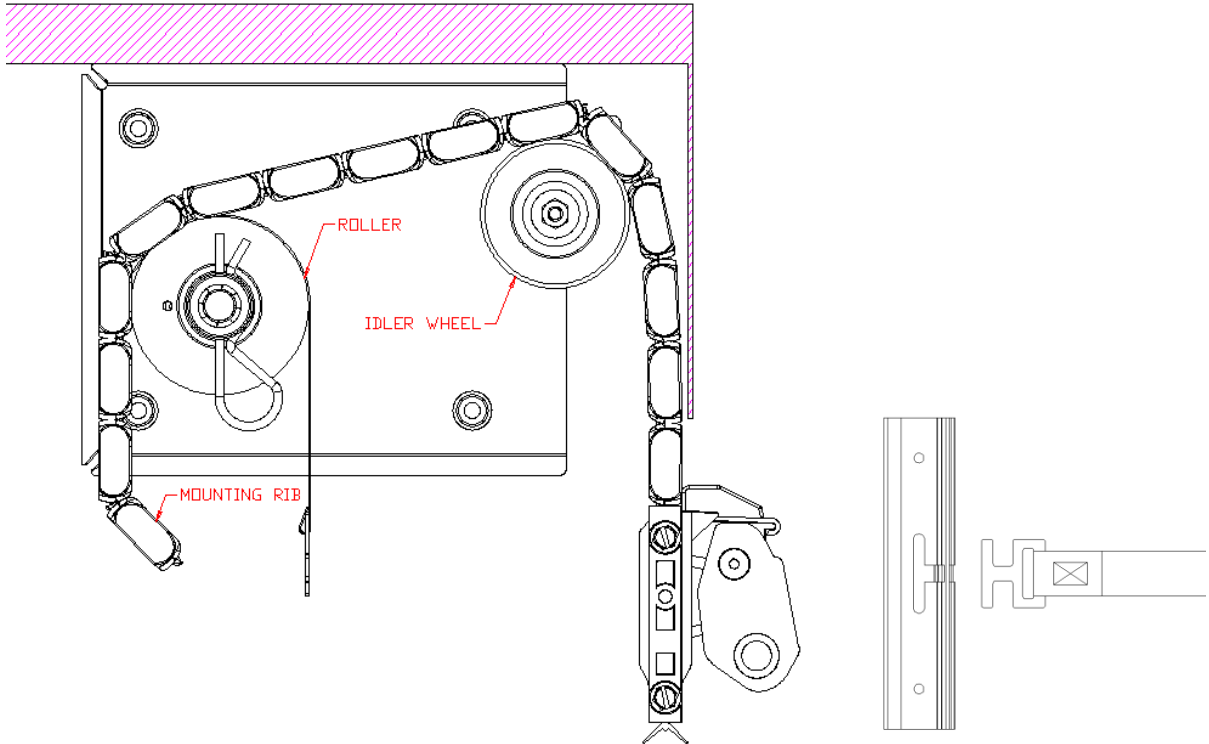

Figure #13

- B) Rotate the roller clockwise to relieve pressure on the hairpin and remove the hairpin. Rotate counter-clockwise and slowly roll the door up into its open position. See Figure #14.

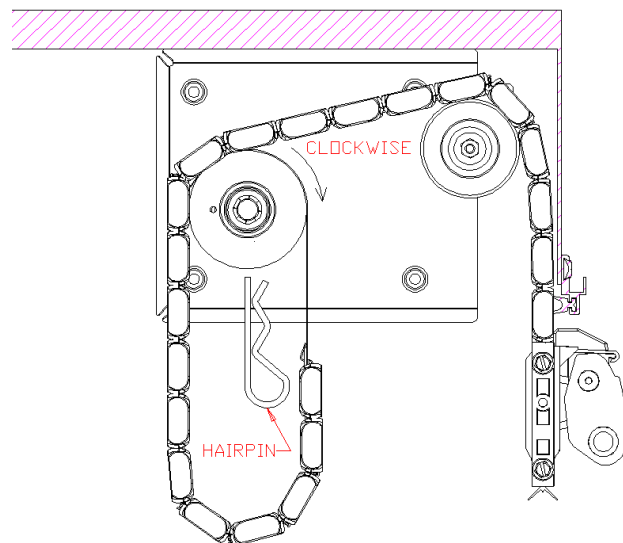

Figure #14

Side Rail Mounting

- A) Install the side rail by inserting the handle into the track and rotating it toward the compartment. Align the holes (predrilled only) and attach to the compartment using fasteners of choice. (Example: #10 Self-tapping sheet metal screws.) See Figure #15.

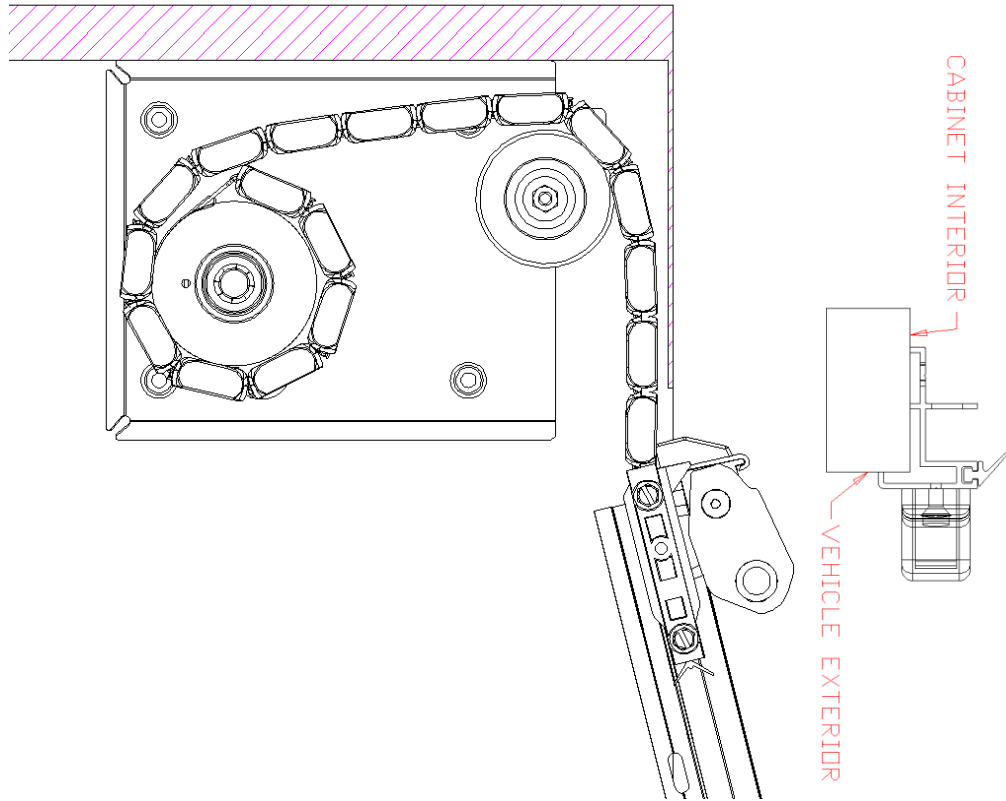

Figure #15

- B) If no pre-drilled holes then drill 11/64" holes 12" a part and use fasteners of your choice. (Example: #10 Self-tapping sheet metal screws.)

Step 9 – Bolt Cover Installation (Optional)

If installation of the roll up door required the removal of a bolt cover, the bolt cover may be snapped into place or slid into place. Any excess or overhanging bolt cover may be trimmed away flush. For additional security, but not required, a drop of PermaBond® 910 under one end of the bolt cover permanently secures the bolt cover in place.



Figure #16

Step 10 – Testing the Door

- A) Release the handle bar from the handle stop latch.
- B) Cycle the door up and down a few times to check functionality.

Clean and Maintain

The Gortite Roll-Up Door requires very little maintenance, and is simple to clean. Any door with a painted surface should not be aggressively cleaned for 30 days from the time of shipment. When cleaning the anodized door slats, use only a mild non-abrasive soap and water. The side channels should also be inspected and cleaned periodically. Use the same type of soap as above and remove the dirt and grime from inside the channels. A silicone spray can be applied to ensure smooth operation. Do not use lithium or grease to lubricate the track. These lubricants only attract dirt. Smooth door operation is the goal, and cleaning any friction spots will help achieve this goal. After they are clean, the friction spots may be sprayed with dry silicone to enhance operation.

Adjusting the Roller Tension

The Gortite Roll-Up Door's tension has been factory set using the width of the compartment and the travel of the roll-up door as a guide, so that the tension is set for the optimal force for opening and closing the shade. However, if there is reason to adjust the tension use the following instructions:

Do Not Make Any Adjustments Until You

- a. Double check the door, looking for possible causes for the increased force required to operate the door. (Example: End caps contacting the side rails due to the door opening being too narrow.)
- b. Check the compartment for perpendicularity. A rectangular opening enhances door operation. Confirm the pennant plate alignment. If not mounted in the recommended fashion, then check the dimensions from the roof and the header so that they are equal on both sides.
- c. The door may need to be lubricated if it is difficult to open and close.
- d. If the door opens with very little force and requires a lot of force to close, the preset tension may be too great. If the door requires a lot of force to open and closes with very little force the preset tension may be too low.

If the spring force is still not satisfactory, the tension on the roller assembly may be adjusted.

To adjust the spring force from outside the compartment.

- 1) Open the door. Remove the fasteners from the side rails and remove the side rails. See Figure #21

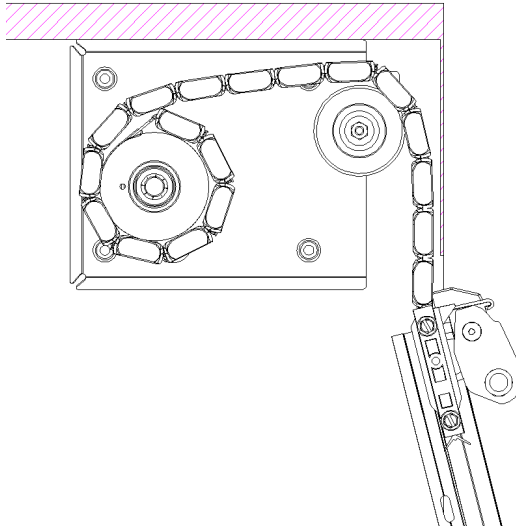

Figure #21

- 2) Slowly pull the door down until the mounting ribs, roller strap, and the roller assembly is accessible.
- 3) Insert the hairpin; remove the roller strap from the mounting rib by gently pushing up on the door to help release the attachment clip from the mounting rib. See Figure #22

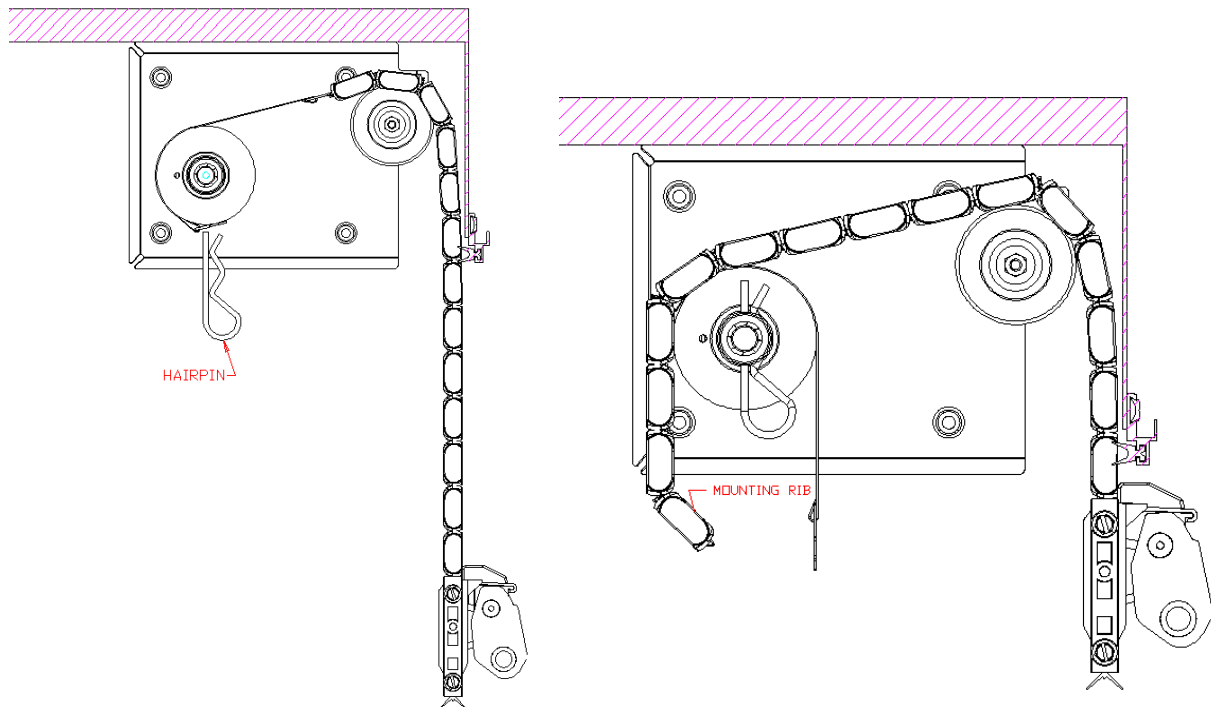

Figure #22

- 4) Hold the roller assembly securely with both hands and have another person remove the hairpin. Turn the roller assembly clockwise one half or one full rotation to increase force or allow the roller to rotate counter clockwise one half or one full rotation to decrease force. See Figure #23

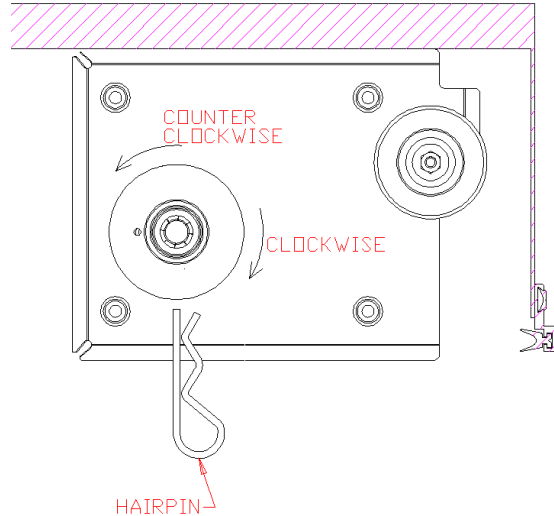

Figure #23

- 5) Insert the hairpin and connect the straps to the mounting ribs.
- 6) Remove the hairpin and slowly let the tension back on the door. Direct the door over the idler rollers and raise the door up to the header.
- 7) Attach the side rails.

Preparation

To switch the ribs, the door and tracks must be placed on their exposed sides on something soft that will not scratch the face of the door and side rails. A blanket, towel or rug will work. Cleaning of the door is recommended during this procedure, as the parts will be readily accessible.

Replacing Ribs

- 1) Remove the top rail. Refer to step 4 of the installation instructions.
- 2) Remove the side rails. Review step 3 of the installation instructions. Remember to protect the exposed flange of the side rails at all times to preserve its finish.
- 3) Remove the door assembly. Review step 6 of the installation instructions. After the door assembly is removed lay it on a soft clean surface.
- 4) Identify the rib that needs to be removed and locate the button on the end cap of the rib to be removed. See Figure #24

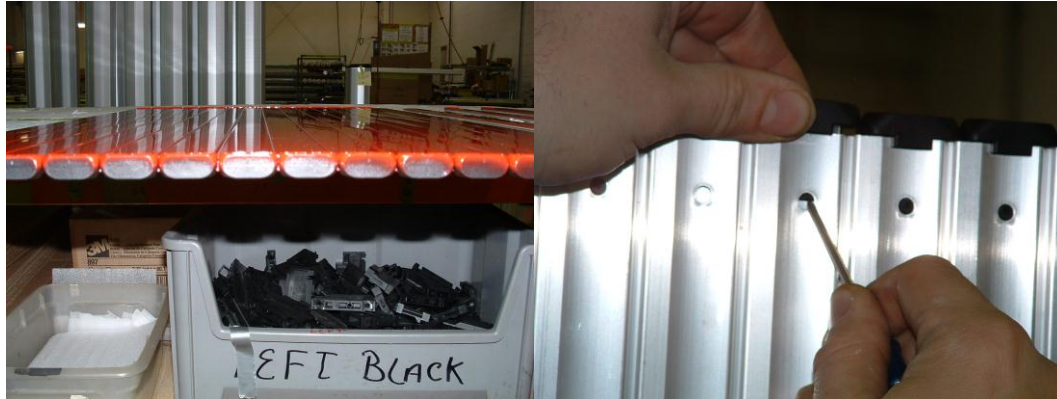

Figure #24

- 5) Remove the end cap by depressing the button with a small screwdriver and pushing out. When the button has been disengaged from the rib then pull to remove end cap. See Figure #25

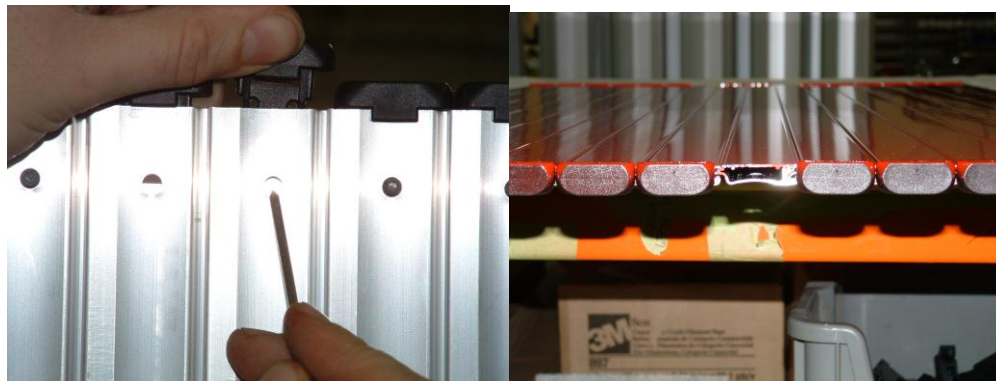

Figure #25

- 6) On the opposite side, the endcaps of the rib directly forward and aft of the rib to be removed need to be removed before removing the rib. For easy removal, create a slight arc in the door where that is to be removed. See Figure #26



Figure #26

NOTE: Endcaps can be reused 3 times.

- 7) Slide the rib seal onto the replacement rib and be sure the rib seal is still attached to the rib forward of the replacement rib.
- 8) For easy installing, slide the rib seals onto the adjoining ribs, create a slight arc, and slide the rib on. See Figure #27

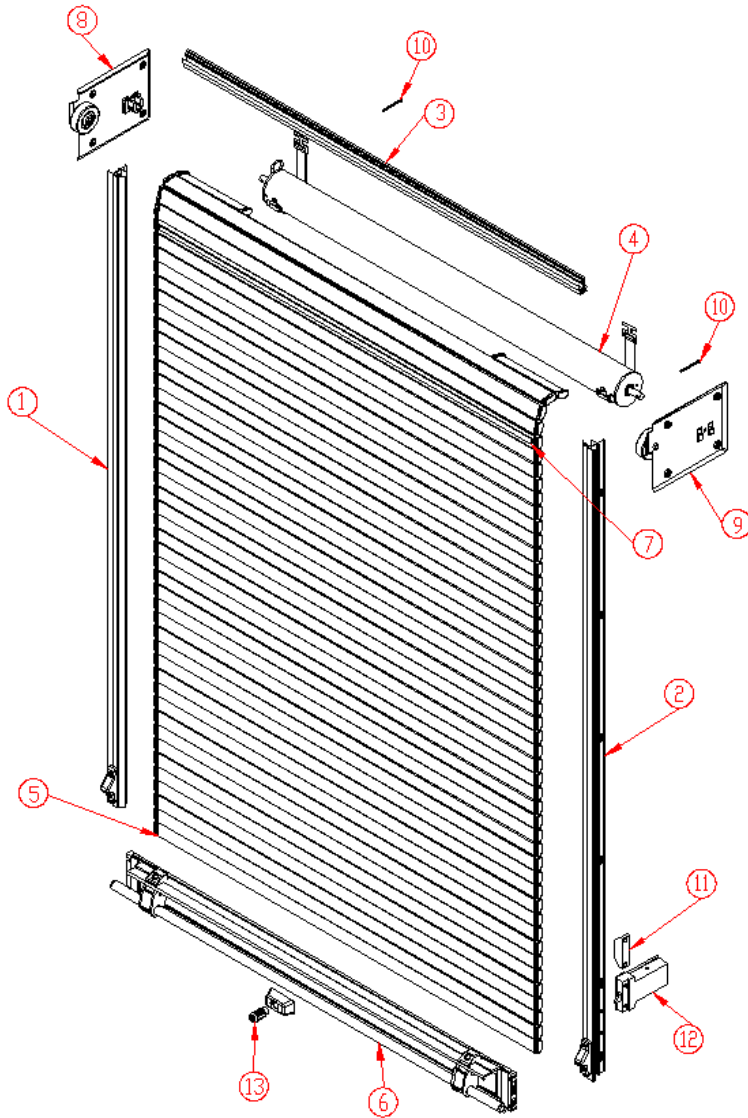

Figure #27

- 9) Align the endcap with rib, insert with a little pressure until it snaps, and check to be sure the endcap is snapped in place. See Figure #28.



Figure #28



ITEM NO.	DESCRIPTION	QTY.
1	SIDE RAIL ASSEMBLY, LEFT	1
2	SIDE RAIL ASSEMBLY, RIGHT	1
3	TOP RAIL ASSEMBLY	1
4	ROLLER ASSEMBLY	1
5	SHADE ASSEMBLY	1
6	HANDLE ASSEMBLY	1
7	DOOR SEAL TAPE	1
8	PENNANT PLATE ASSEMBLY, LEFT	1
9	PENNANT PLATE ASSEMBLY, RIGHT	1
10	1/8" x 1 3/4" Cotter Pin	2
11	DOOR AJAR SWITCH	1
12	POWER DOORLOCK ASSEMBLY	1
13	CAM LOCK	1

Figure #29

If you have any questions, please call A & A Manufacturing at (800) 298-2066